



MTX-D, EGT Gauge User Manual

1	Mounting and Sensor Installation.....	2
1.1	Mounting the Gauge.....	2
1.2	Changing the MTX gauge face and/or bezel.....	2
1.3	EGT probe.....	2
2	Wiring.....	3
2.1	Main Gauge Wiring.....	4
2.2	EGT Sensor Wiring.....	4
3	Download the Logworks software package.....	5
3.1	Installing software.....	5
3.2	Connecting to LM Programmer.....	5
3.3	Programming the Gauge.....	5
3.3.1	Temp Tab.....	6
3.3.2	Updating the Firmware.....	7
3.4	LogWorks.....	8
3.4.1	Logging data.....	8
3.4.2	Adding and Logging MTS channels.....	8
	Appendix A: Limited Warranty.....	10

1 Mounting and Sensor Installation

1.1 Mounting the Gauge

The MTX EGT gauge fits in a standard 2-1/16" (52mm) hole. The gauge can be mounted into a commercially available 2-1/16" (52mm) gauge pod or by drilling a 2-1/16" (52mm) diameter hole to your desired mounting location. Check behind the mounting location for any wiring or components before drilling. Allow at least 2-1/4" (57mm) of depth for the gauge body and associated wiring. Mounting of the gauge should be done in such a manner that the cables are not being forcefully pulled from the gauge body itself.

The MTX EGT gauge is splash resistant (not water proof) and can be mounted so that it is exposed to the elements. The MTX gauge should not be submerged and special consideration should be taken to protect the gauge from direct water spray (water coming from a pressurized source.) When replacing the bezel and/or gauge face verify that the o-ring is properly seated.



Make sure mounting location does not impair visibility or interfere with driving.

1.2 Changing the MTX gauge face and/or bezel

1. Lay the MTX gauge face down and remove the three #2 phillips screws from the outside rim of the back plate.
2. Carefully lift off the bezel from the gauge cup.
3. Configure the gauge as desired by changing the gauge face and/or bezel.
4. Make sure every piece is positioned correctly using the locating tab and reassemble the gauge.
5. Reinstall the 3 #2 phillips screws.

1.3 EGT probe

1. Select the header tube in which you wish to mount the probe.
2. Locate the sensor location point on the pipe.
3. Once the spot is located, drill a .313" (5/16") inch diameter hole in the header pipe.
4. Remove the plastic protector from the probe.

5. Center the weld-in bung over the hole and weld it to the header pipe a full 360 degrees. TIG welding is best.
6. Installation the compression cap and ferrule on the welded base and bring it up to finger tight.
7. Now measure the distance from the tip, up the hot leg of the sensor that is equal to the height of the compression fitting plus the desired immersion depth that the sensor will extend into the exhaust stream. Mark that length using a marker or pen on the sensor sheath.
8. Insert the sensor probe through the installed mounting hardware until the mark touches the top of the cap and tighten compression nut using a 9/16" open-end wrench. Make sure sensor transition and spring is at a 90-degree angle to the exhaust pipe, if room permits. This will position the sender tip correctly in the exhaust stream.



Lead Wire Installation: DO NOT HARNESS THE LEAD WIRE TIGHTLY ! Make long sweeping bends and loosely guide the lead-wire to the instrument using the harness ties provided. This will allow the wire to absorb the engine vibration along the wires length. Prevent the wire from touching the exhaust pipe when the hood is in the down position. The warranty does not cover burnt lead wires or wires that are smashed or twisted off.

2 Wiring

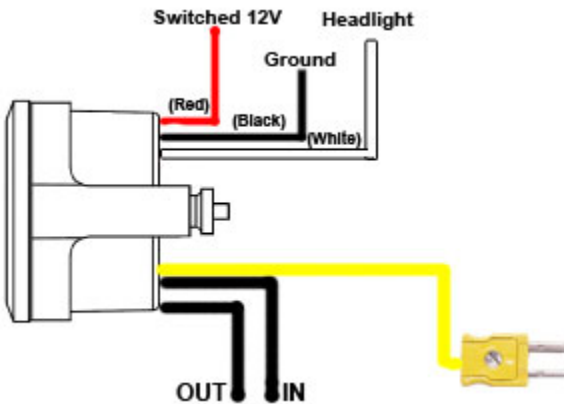

2.1 Main Gauge Wiring

1. Connect the **RED** wire to a switched 12V source. A switched 12V source comes ON as soon as the ignition on the car is keyed on. Make sure the connection is fused with a minimum fuse size of 2A.



Circuits that share power with the vehicle's stereo, ignition system, and fuel pump are not recommended.

2. Connect the main **BLACK** wire to a ground source. Note that there are other black wires coming out of the 2 pin and 3 pin connectors, these are not the main gauge grounds. Avoid noisy ground sources, such as grounds used for the radio and or ignition.
3. Connect the **WHITE** wire to a headlight power wire (a wire that supplies current when the headlights are on). This enables the display to dim for better nighttime viewing. **DO NOT CONNECT THIS WIRE TO THE HEADLIGHT DIMMING WIRE.** Connection to this rheostat type of switch will cause the gauge to malfunction. If you chose not to utilize the dimming feature, connect the WHITE wire to ground.

2.2 EGT Sensor Wiring

1. Fish the EGT sensor's 2 pin connector through the firewall and to the MTX EGT gauge. **DO NOT HARNESS THE LEAD WIRE TIGHTLY!** Make long sweeping bends and loosely guide the lead-wire to the instrument using the harness ties provided. This will allow the wire to absorb the engine vibration along the wires length. Prevent the wire from touching the exhaust pipe when the hood is in the down position. The warranty does not cover burnt lead wires or wires that are smashed or twisted off.
2. Connect the sensor's female 2 pin connector to the male 2 pin connector on the gauge.

3 Download the Logworks software package

1. Open your web browser and go to:
www.innovatemosports.com/support.php
2. The LogWorks software download will be the very first thing on the page, click the link to download the software.

3.1 Installing software

1. Double click on the Logworks installer previously downloaded.
2. The installer will start, follow the prompts to install the software.
3. Once the software has been installed the LogWorks software, LM Programmer and MTX-D manual can then be located by navigating through Start->Programs->LogWorks3.

3.2 Connecting to LM Programmer

LM Programmer is used to change the display's unit of measure from Imperial to Metric, temperature and needle ranges, warnings, and upgrade the firmware

1. Connect the OUT port of the MTX-D to the provided serial programming cable. Connect the other end of the serial programming cable to your computer. If your computer does not have a serial port, you can purchase a USB to Serial adapter from Innovate Motorsports (P/N 3733) or use any USB to serial adaptor that includes drivers. Make sure that nothing is connected to the IN port of the MTX-D
2. Power up the MTX-D.
3. Launch LM Programmer. The LM Programmer application can be launched from *Start->Programs->LogWorks3->LM Programmer* from the Windows task bar.



Avoid connecting or disconnecting any of the ports labeled IN or OUT while the unit is powered ON.

3.3 Programming the Gauge

Whenever a change is made to the programming of the gauge click the **Program** button for the change to take effect. Once the gauge has been programmed the **Program** button will grey out.

To set the gauge back to the factory settings click the **Set To Defaults** button and then click the **Program** button.

3.3.1 Temp Tab

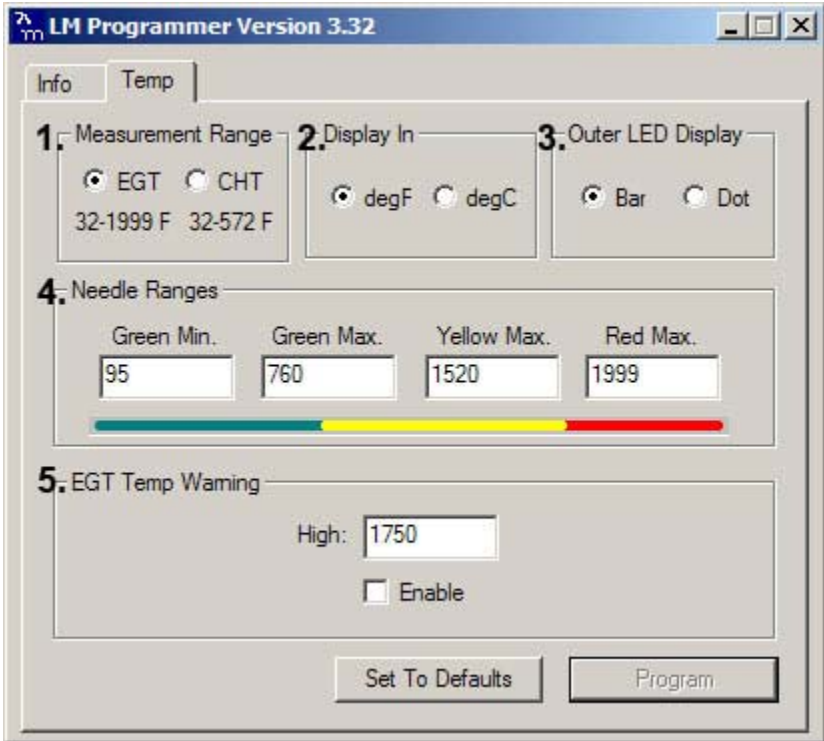

1. **Measurement Range:** In *EGT* range the gauge will display the temperature with a X 10 multiplier to allow for 4 digit numbers. In *CHT* range the gauge will display the three digit temperature (no multiplier).
2. The **Display In** will allow the gauge to display the temperature in either Imperial or Metric unit of measure.
3. The **Outer LED Display** allows the outer LED of the gauge to display as a Bar or single Dot. The Bar will fill the outer perimeter of the gauge as the temperature rises. The Dot will illuminate a single LED (virtual needle) on the perimeter of the gauge.
4. The **Needle Ranges** allows the configuration of each outer LED segment. The temperature range displayed is user defined.

5. The **EGT Temp Warning** will enable the gauge's seven segment and outer LEDs to flash when the entered threshold value has been exceeded. To enable this feature the "Enable" option must be checked.

3.3.2 Updating the Firmware

The LM Programmer Info tab reports the firmware version currently installed on your unit. **Do not update the firmware if the versions are the same. A firmware update should only be necessary if there has been a new release that specifically fixes a problem that you are experiencing with the unit.**

Firmware for the MTX EGT gauge has the extension dld. New firmware releases are available for download on the Innovate Motorsports' web site (www.tuneyourengine.com) under 'Support.'

1. Power OFF the MTX EGT gauge
2. Connect the supplied serial cable to the port labeled OUT.
3. There should be nothing connected to the port labeled IN.
4. Power ON the MTX EGT gauge.
5. Connect the serial cable to your computer. If you are using a serial to USB adapter, connect the serial cable to the adapter then connect the adapter to the computer.
6. Launch LM Programmer. The LM Programmer application can be launched from *Start->Programs->LogWorks3->LM Programmer* from the Windows task bar.
7. Once connected the LM Programmer will display the current version of the firmware that is installed in the LM-2. Do not update the firmware if the versions are the same. A firmware update should only be necessary if there has been a new release.
8. On the very first tab of LM Programmer you will see a button labeled "Update Firmware," click this button.
9. Select the firmware file with the dld extension.
10. Do not disconnect the unit from the computer until the firmware progress screen completely disappears. Once finished you may disconnect the unit from the computer and exit out of the software.

If your computer crashes during a firmware upgrade, the MTX EGT gauge has a recovery mechanism where it will be able to retry the download again and not be disabled by half loaded firmware. Switch the MTX EGT gauge off and on again and then reload LM Programmer. The recovery mechanism is designed to be able to recover 99.9% of the time. While we don't anticipate

this occurring, it is possible that the MTX will not recover correctly and may need to be serviced at our factory. If you suspect this is the case, contact Innovate support.

3.4 LogWorks

The MTX EGT gauge can be connected to the LogWorks software to record and analyze EGT temperatures. The gauge can also be connected to other Innovate Motorsports products to create a log chain with additional gauges and sensors.

3.4.1 Logging data

1. Power OFF the MTX EGT gauge
2. Connect the supplied serial cable to the port labeled OUT.
3. Power ON the MTX EGT gauge.
4. Connect the serial cable to your computer. If you are using a serial to USB adapter, connect the serial cable to the adapter then connect the adapter to the computer.
5. Launch LogWorks. The LogWorks application can be launched from *Start->Programs->LogWorks3->Logworks3* from the Windows task bar.
6. Once LogWorks launches go to *File->Connect*. You will be prompted to connect to serial COM port. Click Connect.
7. *To start recording go to File->New Real-time Log* or, in the Toolbar, click on the  Tool.

3.4.2 Adding and Logging MTS channels

The Innovate Motorsports' MTS (Modular Tuning System) allows you to daisy chain multiple devices together via the serial IN and OUT connectors to form one single synchronous log. MTS log chains can consist of a single unit connected directly to a laptop (connect your *MTX-D* directly to a computer,) two units, or multiple devices connected together, up to 32 channels.

Innovate Motorsports' MTS devices have two types of serial interface connectors, the legacy 2.5mm stereo and the 4 pin Molex. The following patch cables are available to interface your devices together:

4 Pin Molex to 4 Pin Molex - 4ft	p/n 3846
2.5mm to 2.5mm Stereo - 4ft	p/n 3760
2.5mm to 2.5mm Stereo - 6in	p/n 3789
4 Pin Molex to 2.5mm Stereo - 4ft	p/n 3812

To daisy chain MTS devices together

1. Power OFF all your MTS devices.
2. Start with the first product in the serial chain. Using the appropriate mating cable, connect the OUT port from the first device and feed it into the IN port of the second device. *(Note: If you have an LC-1, there must be a terminator plug in the serial IN if it is the first device in the serial chain.)*
3. Continue connecting the OUT port of each device into the IN until all your devices are connected together.
4. If a recording device is not connected to the serial chain, e.g. DL-32, LM-2, the OUT port of the last device can be connected directly to a computer to log with the LogWorks software
5. Once all the connections of the ports labeled IN and OUT are made the MTS devices can be powered ON.

Appendix A: Limited Warranty

LIMITED WARRANTY

Innovate stands behind the quality of its products. Innovate makes the following warranty to purchasers of its products: All new Innovate products carry a one year warranty from the date of purchase. If proof of purchase cannot be provided, warranty will be determined by date of manufacture.

When Warranty Void

This warranty shall terminate and Innovate shall have no obligation pursuant to it if (i) your Innovate product has been modified or repaired in a manner not previously authorized by Innovate in writing; (ii) the identification markings on your Innovate product have been removed, defaced, or altered; (iii) your Innovate product was subjected to accident, abuse, shipping damage, or improper use; (iv) your Innovate product was not used or configured as specified in the product manual; or (v) your Innovate product was subjected to operating conditions more severe than those specified in the product manual.

Exclusions From This Warranty

Oxygen Sensors are excluded from this warranty.

Repairs Under This Warranty

In the unlikely event that your Innovate hardware product should prove defective during the warranty period, contact Innovate Customer Support for a return material authorization (RMA) at (800) 348 3037. Products returned for service must be securely packed to prevent damage and shipped charges pre paid, along with proof of purchase and the return material authorization form, to the Innovate repair location as instructed by Customer Service. Innovate within a reasonable amount of time from its receipt of your product so shipped, will ship to you, at its option, the repaired product or a new or reconditioned product of comparable or greater specified functionality. All repaired or replacement products shall be warranted for the remainder of the original product warranty.

Disclaimer

INNOVATE MAKES NO OTHER EXPRESS OR IMPLIED WARRANTY WITH RESPECT TO YOUR INNOVATE PRODUCT OTHER THAN THE LIMITED WARRANTY SET FORTH ABOVE. No Innovate dealer, agent, or employee is authorized to make any modification, extension, or addition to this warranty, unless enforceable or unlawful under applicable law, INNOVATE DISCLAIMS ALL IMPLIED WARRANTIES, INCLUDING THE IMPLIED WARRANTIES OF MERCHANTABILITY, NONINFRINGEMENT, AND FITNESS FOR A PARTICULAR PURPOSE, AND THE LIABILITY OF INNOVATE, IF ANY, FOR DAMAGES RELATING TO ANY ALLEGEDLY DEFECTIVE PRODUCT SHALL UNDER ANY TORT, CONTRACT, OR OTHER LEGAL THEORY BE LIMITED TO THE ACTUAL PRICE PAID FOR SUCH PRODUCT AND SHALL IN NO EVENT INCLUDE INCIDENTAL, CONSEQUENTIAL, SPECIAL, OR INDIRECT DAMAGES OF ANY KIND EVEN IF INNOVATE IS AWARE OF THE POSSIBILITY OF SUCH DAMAGES. Some states do not allow limitations on how long an implied warranty lasts or the exclusion or limitation of incidental or consequential damages, so the above limitations or exclusions may not apply to you.